

In-Housing AMC 1214B-8A

Broadband 110 – 170 GHz

Active Multiplication Chain (AMC) in WR-6.5 Based on ACST's High-Power Multiplier Technology.

1214x-A series of Amplifier/Multiplier Chains (AMCs) are designed to extend operation frequency of a microwave signal synthesizer or a sweeper, providing high performance sources for applications at mm-waves signals. The AMC applies ERZIA High-Power Broadband Amplifier Technology and ACST High-Power Broadband Multiplier Technology resulting in best available performance with respect to output power, bandwidth, and spectral purity. AMC output frequency is determined by the multiplication factor (n) of the input signal, while phase noise degradation (with respect to the input signal) adheres to 20 Log (n).

Based on a modular design, each AMC from this series is integrated in an esthetic metallic housing featuring standard input and output interfaces. They are fixed tuned and do not require any adjustment for proper operation. All required voltage biases and current sources are provided by an integrated Power Supply Unit (PSU). The module only needs electrical powering of 18V DC, which is provided by a universal AC/DC adapter, included in the delivery package. Options like Horn antenna (for coupling the output signal to free space), waveguide sections compatible with the output RF-port may be integrated on customer request.

Type **1214B-8A** module requires an input signal within the frequency range of 13.75 to 21.25 GHz, generating an output signal within the frequency range of 110 to 170 GHz. In addition to standard options for 1214x series, a variable 1-25dB attenuator is offered for user-controlled output power. The standard multiplication factor is 8, but a factor 12 option is also available under specific customer requirement (1214B-12A).

Various options can optionally be offered and integrated on customer request:

- Horn antenna (for coupling the output signal to free space),
- Waveguide sections compatible with the output RF-port
- User controlled output power by integration of a mechanically driven variable attenuator

Please consult sales@acst.de for available options for this product type

Technical Specification

	Minimum	Typ	Maximum
Input Port (Coaxial)		SMA	
Input Frequency (GHz)	13.75		21.25
Input Power (dBm)	0	+4	+6
Output Port (UG 387/U-M)		WR-6.5	
Output Frequency (GHz)	110		170
Output Power (dBm)	+8	+10	+14
Multiplication Factor** (n)		8	
Total Power Consumption (W)			30



Product Features

- > High-Power & Efficiency
- > Full band
- > Flat response

Application Areas

- > Laboratory instrumentation
- > MM-wave FMCW-Radar
- > Active imaging
- > LO Source for MM/SubMM wave heterodyne receivers

* Lower Efficiency may be expected at input power lower than specified and near the band edges.

** Higher multiplication factors are also possible under request

In-Housing AMC 1214B-8A

Broadband 110 – 170 GHz

Typical Performance

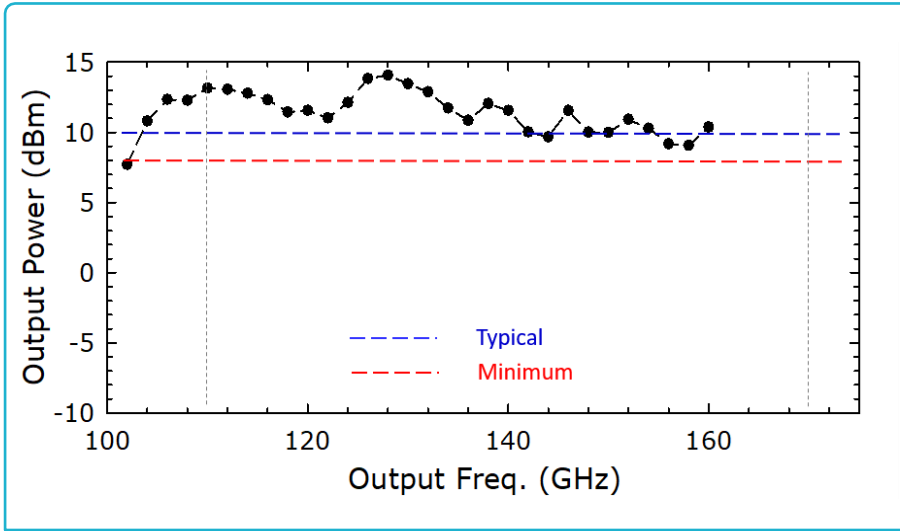

Notes

- > All plotted data represent typical values. The actual data may vary from unit to unit.
- > All tests are carried out at a room temperature of 24 °C.

Caution

- > Absolute maximum ratings should not be used under normal operating conditions. Exceeding maximum ratings may lead to permanent failure.
- > Any foreign body inserted into the waveguide will cause a loss of performance and may damage the device.

Absolute Maximum Ratings

	Maximum
Input Power (dBm)	+10
Operational Temperature and Humidity	5 °C to 45 °C // 0% to 80%
Storage Temperature and Humidity	5 °C to 65 °C // 0% to 80%

Order information

- Please indicate product name and type.
- Please indicate desired optional features



ACST GmbH reserves the right to make changes to the product or information contained herein without notice. Visit www.acst.de for additional data sheets and product information.

In-Housing AMC 1214B-8A Broadband 110 – 170 GHz

Outline Dimensions

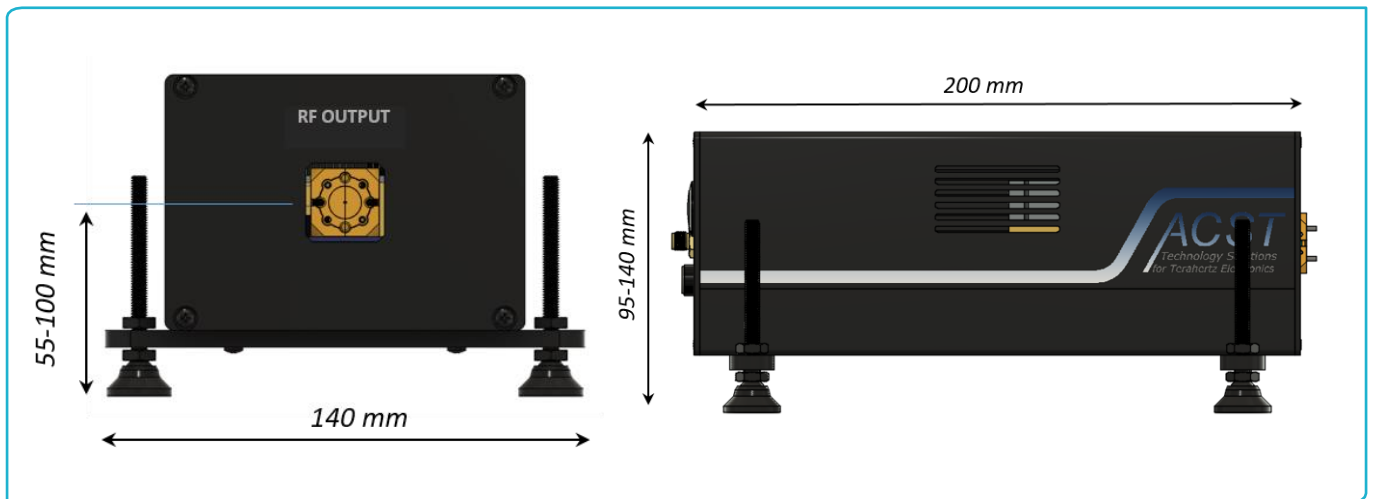

Mechanical Description

	Maximum
Size (W x H x L without connectors, mm)	140 x 95 (140) x 200
Overall weight (kg)	2
Output Waveguide Orientation	H-Plane